

LA-BW16-12S BALL WALL ELEVATION

ITEM	QTY.	PART NO.	DESCRIPTION
1	3	F02BW458	4" x 4" x 5/16" STRUCT. TUBE @ 16'-0"
2	20	P02BW418	METAL STUD @ 7'-6" (GALVANIZED)
3	40	P02BW801	1-1/2" x 1-1/2" x 3" @ 8 GA. CLIP
4	12	P08BW408	4' X 8' X 1/2" AC EXTERIOR PLYWOOD
5	2	F02BW160	18 GA. GALV. SHEETMETAL CAP/ 2 PIECES @ 8'-0" w/ SEAM COVER
6	2	F02BW121	18 GA. GALV. SHEETMETAL CAP @ 12'-0"
7	75	P01BW101	5/16" HEX A/F 4 POINT SCREW
8	1100	P01BW102	QUADREX OUTDOOR SCREW - PLY TO FRAME
9	75	P01BW103	PANHEAD No. 10 X 1/2" - CAP AND SIDES TO PLYWOOD
10	1	P01BW988	TUBE OF SILICONE

DATE: 2/22/17

DRAWN BY: AFS

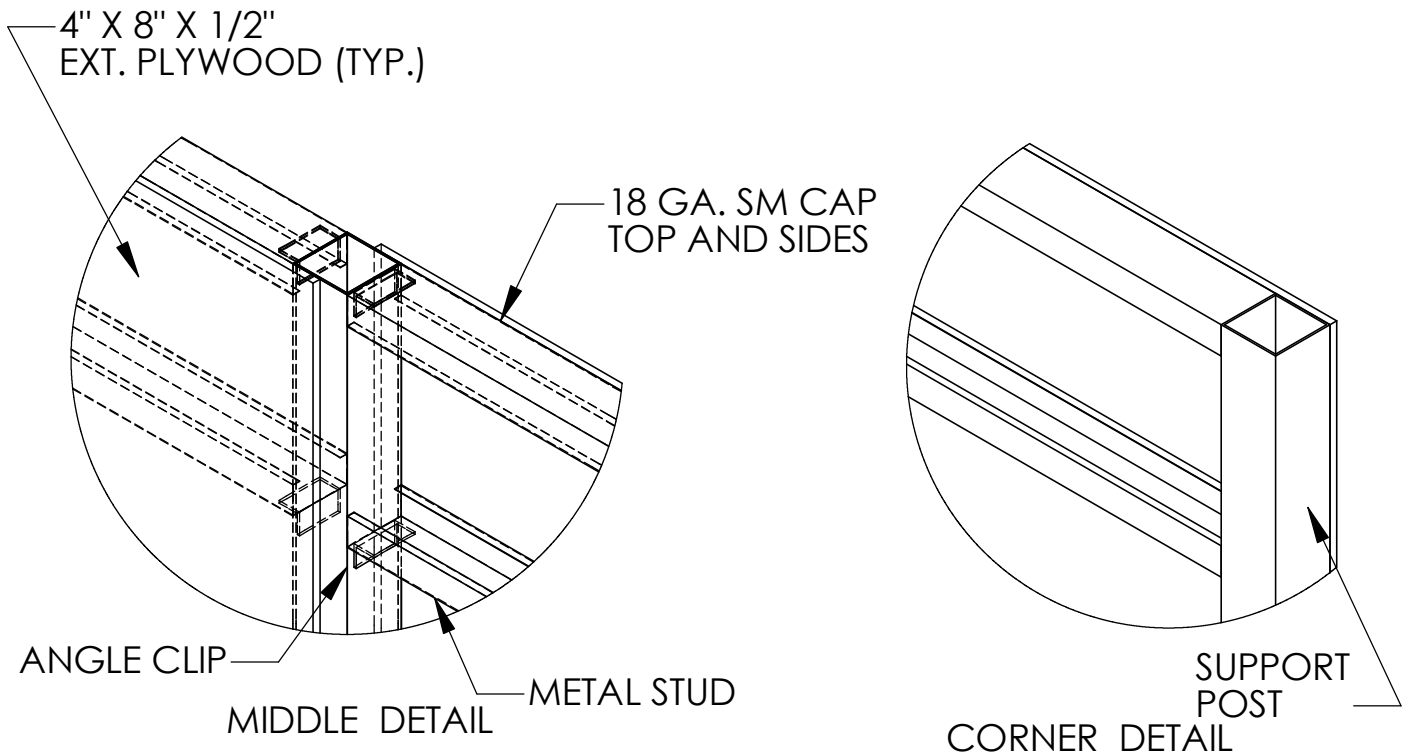

ASSEMBLY INSTRUCTIONS:

1. THERE ARE THREE SQUARE STEEL POSTS. ONE HAS "CLIPS" ON BOTH SIDES AND TWO HAVE CLIPS ON ONE SIDE ONLY. THE ONE WITH CLIPS ON BOTH SIDES IS THE CENTER POST AND THE OTHER TWO ARE THE END POSTS.
2. DIG THREE FOOTINGS AS SHOWN ON SHEET 1. PLACE THE PROPER POST INTO THE FOOTING HOLE AND SUPPORT THEM IN A PLUMB AND LEVEL POSITION AT THE PROPER SPACING. BE SURE THEY ARE PROPERLY ALIGNED AND AT THE PROPER HEIGHT ABOVE FINISHED GRADE. THE BOTTOM "CLIP" HAS TO BE 1 inch ABOVE THE HIGHEST FINISHED GRADE. IF THE POSTS ARE NOT PLUMB AND TOPS AT THE SAME ELEVATION, YOU WILL HAVE PROBLEMS COMPLETING THE INSTALLATION.
3. POUR CONCRETE INTO THE FOOTING HOLES AND WAIT 37 HOURS BEFORE PROCEEDING.
4. ATTACH THE LIGHT GAGE METAL STUDS BY SCREWS THROUGH THE STUD INTO THE "CLIPS". THE TOP STUD SHOULD HAVE THE FLAT SIDE UP. ALL THE REMAINING STUDS HAVE THE FLAT SIDE DOWN. TWO SCREWS PER CLIP IS NECESSARY.
5. APPLY A "DAB" OF SILICONE CAULKING TO THE FACE OF THE STUDS AT APPROXIMATELY 10" ON CENTER. THIS IS TO IMPROVE THE SOUND DAMPENING OF THE WALL WHEN USED.
6. ATTACH THE PLYWOOD SHEETS TO THE FRAME. MAKE SURE THE OVERLAY IS TO THE OUTSIDE OF THE WALL. USE THE QUADREX™ LIFECOAT™ SCREWS AND SHOULD BE AT 8" MIN SPACING. (NOTE: SUGGEST PRE-DRILLING WITH 1/8" DRILL LOCATIONS WHERE SCREW ATTACHES PLYWOOD TO VERTICAL STEEL SUPPORTS)
7. SCREW THE SHEETMETAL CAPS TO THE TOP AND SIDES TO COMPLETE THE INSTALL.
8. PAINT SURFACES WITH TWO COATS OF PROPER PAINT. PAINT IS SUPPLIED BY OTHERS.

NOTE: SPECIFICATIONS ARE SUBJECT TO CHANGE

RE-BAR CAGE SUPPLIED BY OTHERS

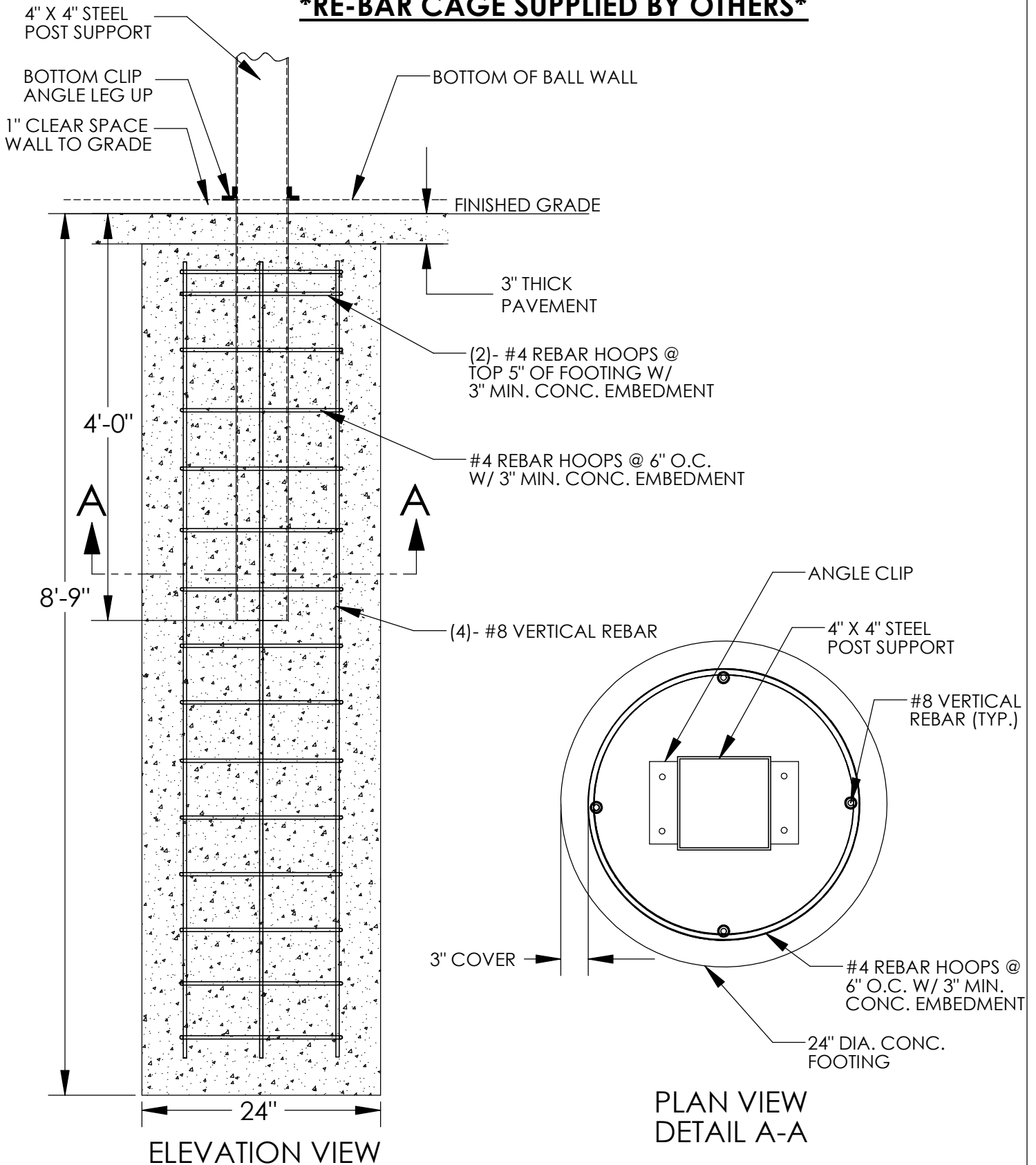

NOTE: SPECIFICATIONS ARE SUBJECT TO CHANGE

DO NOT SCALE DRAWING

DATE: 8/5/10

DRAWN BY: A.F.S

*** NOT FOR DSA SUBMITTAL ***